

BOARD & BATTEN

Installation Manual

269 215-2003

info@themetalsshopllc.com

themetalsshopllc.com

Follow us on:   

BUY DIRECT

AND SAVE!

Contact Us:



(269)215-2003



info@themetalshopllc.com



www.themetalshopllc.com



**12945 S M-66 HWY
Bellevue, MI 49021**

Follow us on:   

TABLE OF CONTENTS

Preparation	01
Furring and Installation Techniques	02
Base Chalk Line	05
Inside Corner	07
Outside Corner	08
Starter Strip	09
Window and Door Trim	10
• Gable End Trim	12
Cutting Procedures	13
Installing the Siding	15
Nailing and Stapling	16
Panels at Windows and Doors	18
Fitting at Gable Ends	20
Fitting Under Eaves	21
Vertical Siding	22
Caulking and Clean up	25
Repairs and Miscellaneous	26
Soffit and Fascia	28

PREPARATION

SURFACE PREPARATION

- The quality of the finished job depends on good preparation of the work surface. Check for low places in the plane of the wall and build out (shim out) if required. Prepare the entire building a few courses at a time. Securely nail all loose boards and loose wood trim.



SURFACE PREPARATION

- Replace any rotted boards. Scrape away old paint buildup, old caulking, and hardened putty, Especially around windows and doors where it might interfere with the positioning of new trim. New caulk should be applied to prevent air infiltration.

REMOVE DOWNSPOUTS/TIE BACK SHRUBS

- Remove downspouts and other items that would interfere with installation of new siding.
- Tie back shrubbery and trees from the base of the building to avoid damage to the landscaping.



REMOVE DOWNSPOUTS/TIE BACK SHRUBS

WINDOW SILL PREPARATION

- Window sill extensions may be cut off so J-trim can be installed flush with window casing.
- Alternatively, to maintain the original window design, coil stock can be custom-formed around the sill instead of cutting away the sill extensions.

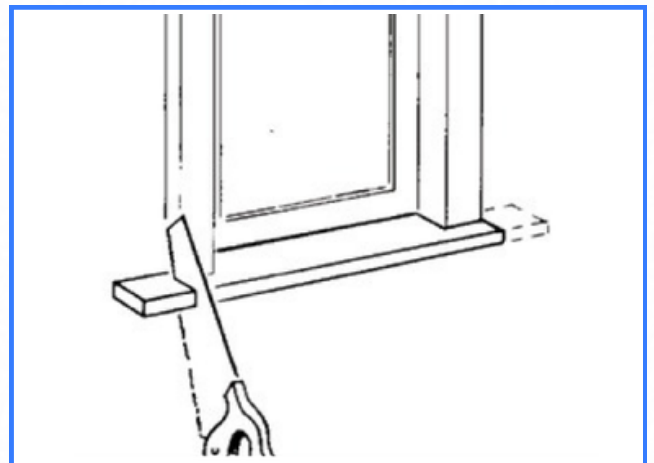

WINDOW SILL PREPARATION

FURRING AND INSTALLATION TECHNIQUES

WOOD FURRING

- Furring is building out from the wall surface to provide a smooth even base for nailing on the new siding. Lath Strips $\frac{3}{8}$ " thick are most commonly used. Lumber strips 1" x 3" are often used over brick and masonry. Furring is not usually necessary in new construction, but older homes often have uneven walls, and furring out low spots, or shimming, can help prevent a wavy appearance to the siding installation. Insulation value can be added by furring out an entire wall (see diagrams on page 14).
- Furring should be installed vertically 16" on center for horizontal siding, and the air space at the base of siding should be closed off with strips applied horizontally. Window, door, gable, and eave trim may have to be built out to match the thickness of the wall furring.

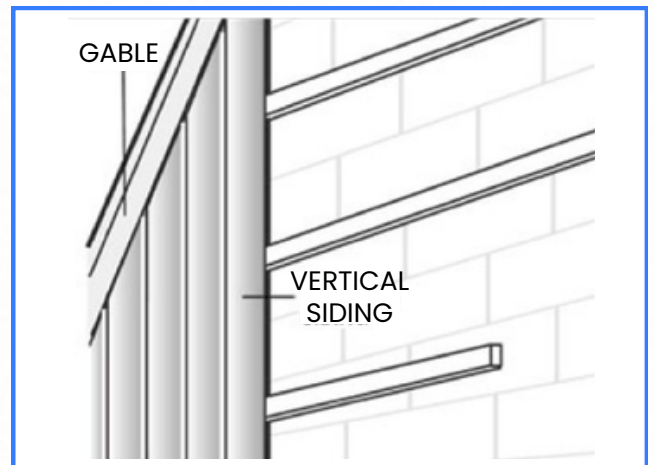
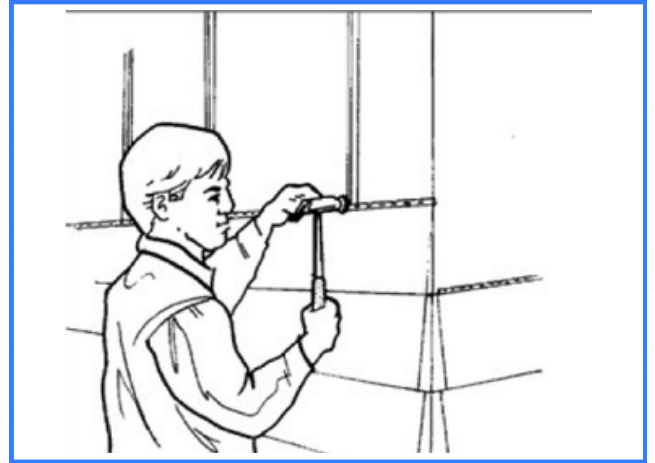

VERTICAL SIDING

- Furring for vertical siding is essentially the same as for horizontal siding, except the wood strips are securely nailed horizontally into structural lumber on 16" to 24" centers. When using 1"x 3" furring, again be sure to check what effect the additional thickness might have on trim situations.

FURRING AND INSTALLATION TECHNIQUES

UNDERLAYMENT

- ▶ Fanfold 3/8" thick
- ▶ Housewrap
- ▶ Siding is to be installed directly over properly installed underlayment. We specify that an underlayment be used on all applications prior to the installation of the siding. We also specify the following:
 1. All seams and channeling should be taped to help prevent air and water infiltration.
 2. All outside and inside corners should be wrapped continuously.
 3. Underlayment is to be installed over roof or brick flashing, and then taped to help prevent water and air infiltration.
 4. Underlayment is to cover the top of the wall to the bottom of the wall, including all gables.
 5. When using Housewrap, seams are to be overlapped a minimum of 1' and then taped.
 6. We specify using plastic cap fasteners to attach the fanfold underlayment to the wall.
 7. Prior to the installation of siding on a retro project, the fanfold must be applied over the top of the existing siding so there is a flat surface to apply the new siding onto.
 8. the fanfold is applied with the foil facing inward.
- ▶ EMCO Building Products does not recommend installing drop-in foam backer for any of its siding panels.

Note: Whenever installing any type of insulation or housewrap products follow the manufacturers installation instructions.

FURRING AND INSTALLATION TECHNIQUES

WINDOW AND DOOR BUILD-OUT

- Some trim build-out at windows and doors may be required to maintain the original appearance of the house when using furring strips or underlayment board. This is particularly true when using furring strips or underlayment board more than 1/2" thick.
- Thicker furring and underlayment generally provide added insulation value, and are usually a good investment for the homeowner, particularly if the home is non-insulated. When estimating the labor and materials required for installing furring and underlayment, be sure to include an estimate on window and door build-out. Longer siding nails will be needed to compensate for added thickness of insulation board.

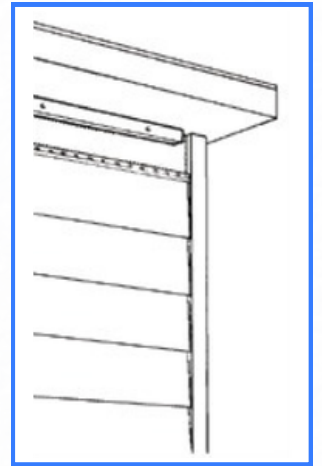
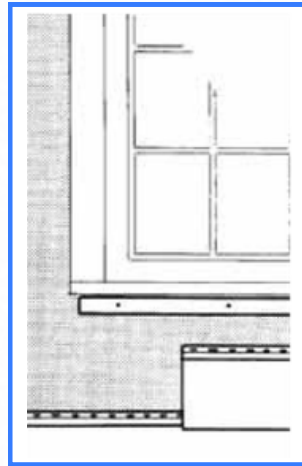

UNDERSILL FURRING

- Building out below window sills is often required in order to maintain the correct slope angle if a siding panel needs to be cut less than full height. The exact thickness required will be apparent when the siding courses have progressed up the wall and reached this point.

UNDEREAVE FURRING

- For the same reason, furring is usually required to maintain the correct slope angle of the last panel where it terminates at the eave. This panel usually has to be cut to less than a full height, thus requiring backup furring and a special piece of trim for capping.

BASE CHALK LINE

STRAIGHT LINE

- **Note:** The key element in a successful siding installation is establishing a straight reference line upon which to start the first course of siding.
- The suggested procedure is to measure equal distances downward from the eaves and/or windows. This ensures that the siding appears parallel with the eaves, soffit, and windows, regardless of any actual settling of the house from true level.

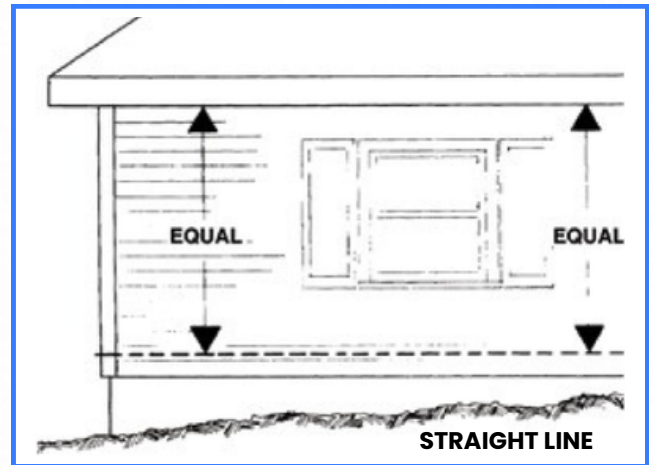

CHALK LINES

- Find the lowest corner of the house. Partly drive a nail about 10" above the lowest corner, or enough to clear the height of a full siding panel. stretch a taut chalk line from this corner to similar nail installed at other corner. Reset this line based upon measuring down from points of equal dimension from eaves or windows. Repeat this procedure on all sides of the house until the chalk lines meet at all corners. Before snapping chalk lines, check for straightness. Be alert to sag in the middle, particularly if line is more than 20' long.
- If preferred, lines may be left in place while installing the starter strip, as long as they are checked periodically for excess sag.

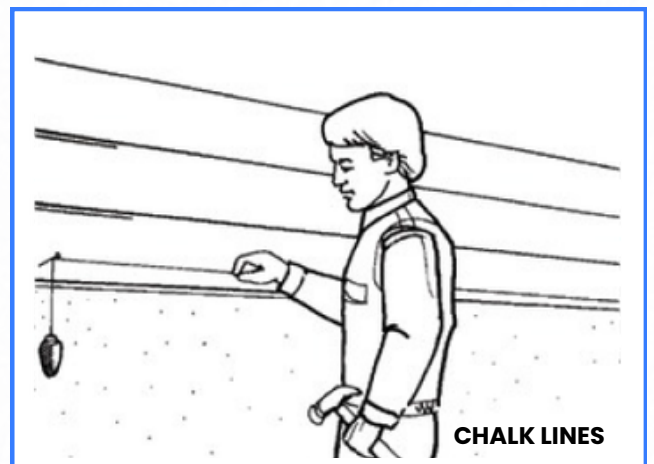

BASE CHALK LINE

LEVEL

➤ If the house is reasonably level, an alternative is to use a level to set the chalk line approximately 2" (or the width of the starter strip) from the lowest point of the old siding, and locate the top of the starter strip to that line. Be careful when using a standard carpenter's level because the progressive measurements may increase the possibility of error. The level should be at least 2' long, and preferably longer. Take level reading at center of chalk line for best results.

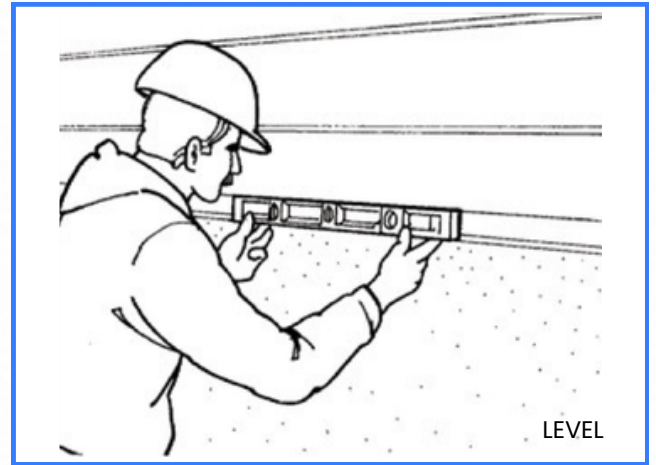

INSIDE CORNER

INSTALLATION

- Two J-Channels at right angles may also be used as an inside corner. A bead of caulking will assist in preventing water penetration at the junction. Deeper or narrower J-channel may be required, depending on type of siding.
- The J-channel is set in the corner full length, reaching from 1/4" below bottom of starter strip up to eave or gable trim. Nail approximately every 12" on both flanges. Make sure J-Channel is set straight and true. Flanges should be nailed securing to adjoining wall, but do not overdrive nails so as to cause distortion.

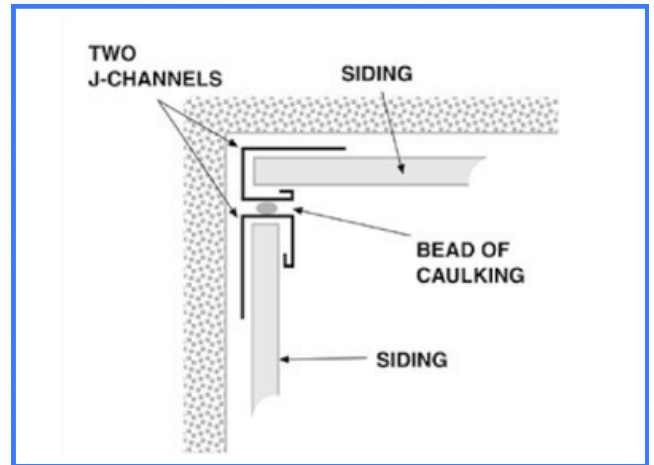

EXPANSION ALLOWANCE

- The siding is butted into the corner and nailed into place allowing space between the JChannel and the siding for expansion purposes. For more information on expansion and contraction requirements, see page 20.

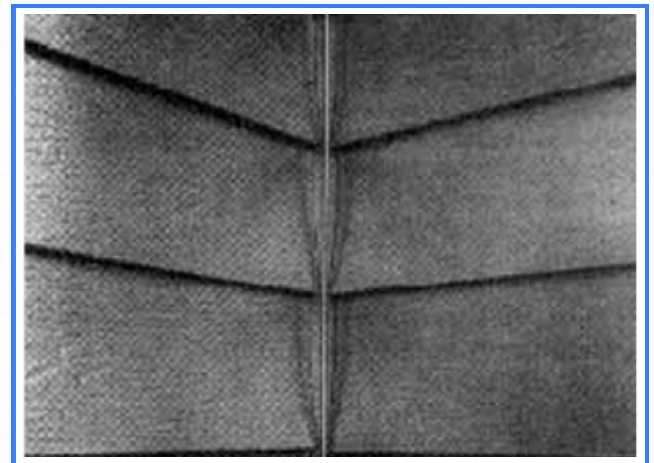

OUTSIDE CORNER

BASE

- Nail every 12" in nail slots on both sides of corner base. Make sure both sides are securely nailed, but avoid distortion caused by overdriving nails. If insulation is being used, wide bases may be needed. Base should extend 1/4" below the starter strip.

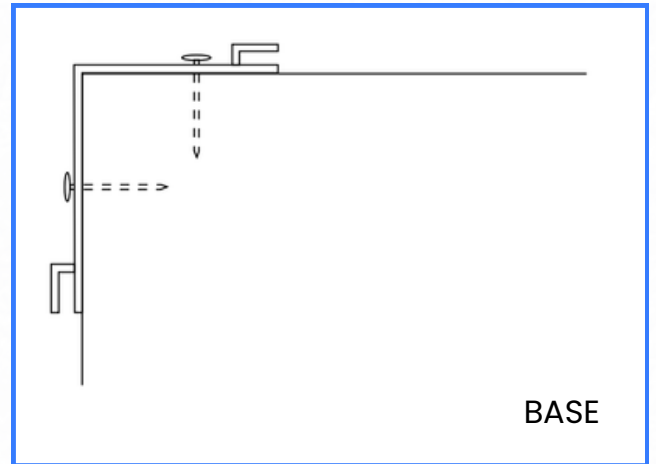

CAP

- The outside corner post produces a trim appearance. Unlike outside corner posts with the cap and base design, if your cap gets damaged, just snap off the damaged one and snap on the new one. Set a full-length piece over the corner base running from 1/4" below the bottom of the starter strip to the underside the eave. If a longer corner cap is needed, overlap corner post sections with the upper piece outside.

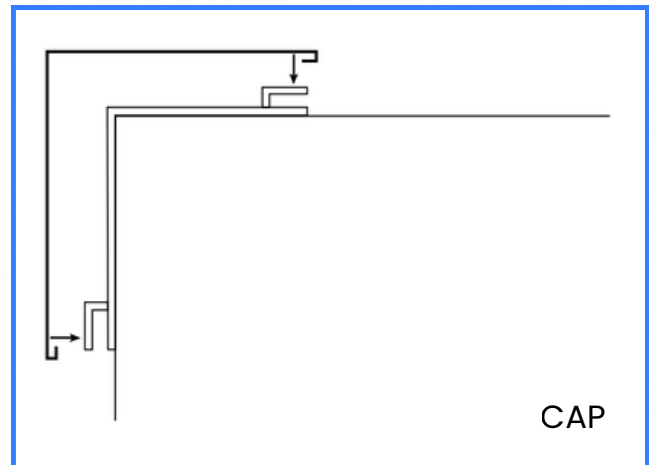

INSTALLATION

- The outside corner post produces a trim appearance and will accommodate the greatest variety of siding types. Most outside corner posts are designed to be installed before the siding is hung, in a manner similar to the inside corner post. If desired, old corner posts may sometimes be removed. Set a full-length piece over the existing corner running from 1/4" below the bottom of starter strip to the underside of the eave. If a longer corner post is needed, overlap corner post sections with the upper piece outside.

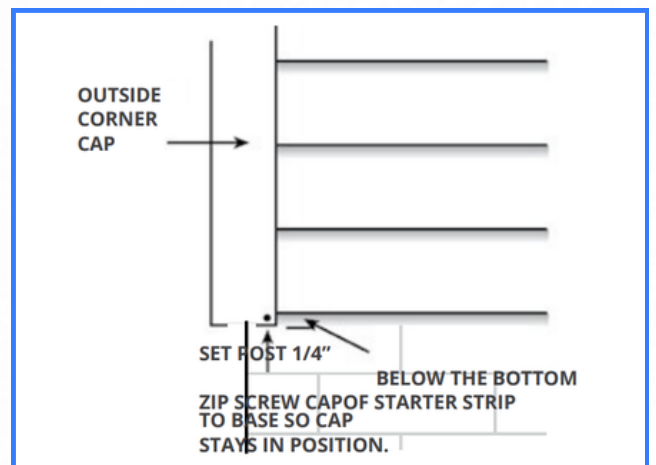

STARTER STRIP

HORIZONTAL SIDING

- Using the chalk line previously established as a guide, take equal distance measurements (see "a" in diagram) and install starter strip all the way around the bottom of the building. The starter strip should be furred out the thickness of the backer. It is extremely important that the starter strip be straight and meets accurately at all corners, since it will determine the line of all siding panels installed. Where hollows occur in the old wall surface, shim out behind the starter strip to prevent a wavy appearance of the finished siding application.

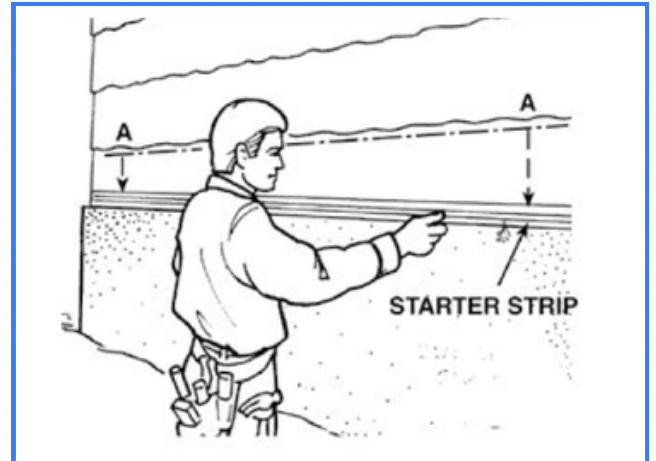

VERTICAL SIDING

- A plumb line should be used when applying starter strip in a vertical position

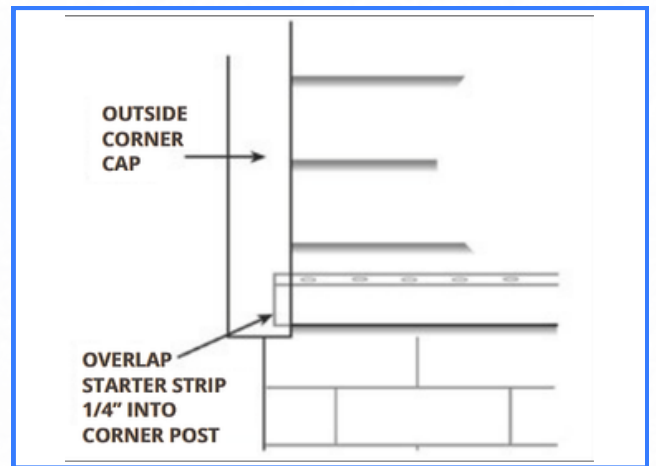

NAILING

- The starter strip should overlap the corner base flanges to help reduce air infiltration. Use nails spaced not more than 8" apart to securely fasten the starter strip. Nail starter strip as low as possible. Be careful not to bend or distort. Do not overdrive nails. Cutting lengths of starter strip is best accomplished with tin snips. Butt sections together.

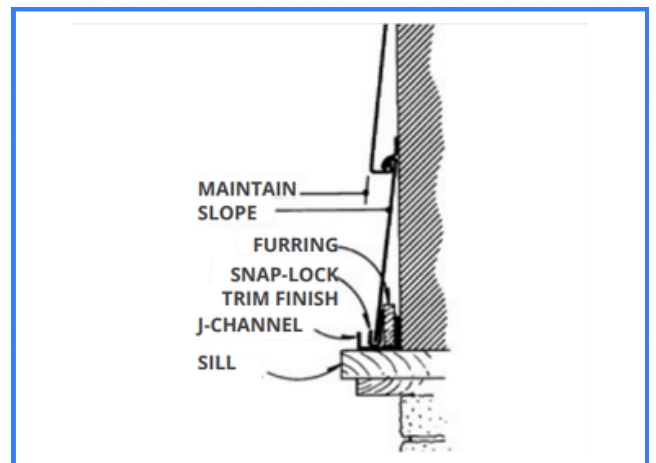

ALTERNATIVES

- Starter Strip may not work in all situations. Other accessory items such as J-Channels or SnapLock finish trim may work better in starting siding courses over garage doors and porches, or above brick, for example. These unusual situations must be handled on an individual basis as they occur.

WINDOW AND DOOR TRIM

COIL STOCK

➤ For a superior job in remodeling work, the old window sills and casings can be covered with aluminum or steel coil stock, bent to fit, on the jobsite. The advantage is freedom from maintenance.

➤ Sometimes window and door casings need to be built out to retain the original appearance of the house or to improve the appearance. To do this, use appropriate lengths and thickness of good quality lumber, and nail securely to existing window casings. Remove storm windows before covering casings with coil stock sections custom formed on the jobsite.

➤ Forming coil sections to fit window casings is done with a portable brake as follows. Door casings are handled similarly.

➤ **1. Sill Cover** – Form trim to dimensions of wood sill being covered. For flashing purposes, snip and fold upright tabs at jamb locations and sill ends as shown. Install with small head trim nails and/or adhesive.

2. **Casing Cover** – Form casing trim to dimensions of wood jamb being covered. Install over vertical flashing tabs of sill cover trim. Fasten in place as above.

3. **Window Head Cover** – Form to dimension of wood head being covered. Miter corners as shown, on both sides. install so as to lap over casing trim pieces and fasten in place.

4. **Caulk** – Caulk where necessary to prevent water penetration behind trim pieces.

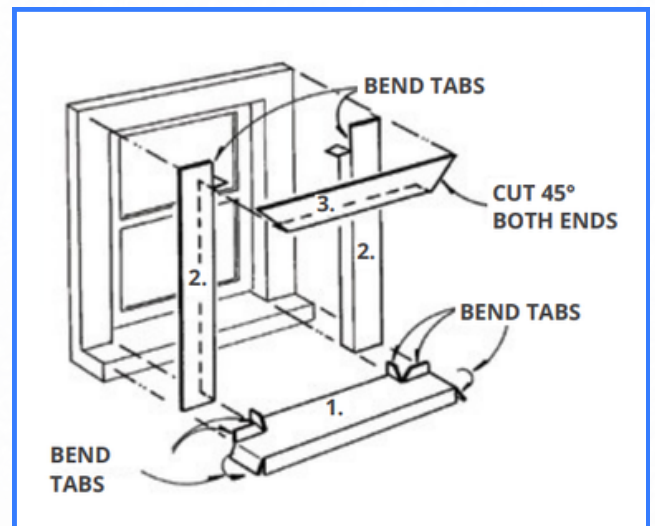

WINDOW AND DOOR TRIM

TWO-PIECE SILL

- ◉ If there is a step in the wood sill, it can be covered best by bending two separate sill cover pieces as shown. Let the flanges lap over for best water runoff.

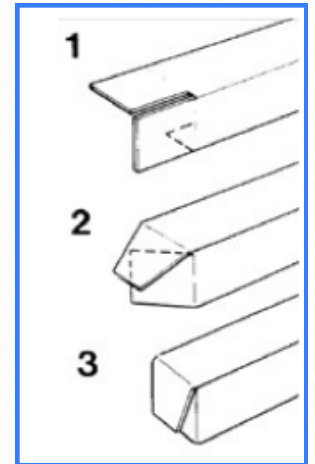
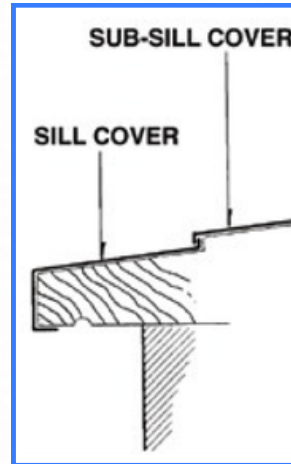

SILL ENDS

- ◉ By using tin snips and bending flanges on the job, the old sill ends can be boxed-in to provide a neat appearance and to prevent water penetration.



Note: Care must be exercised in placing aluminum or steel in contact with materials such as dissimilar metals, concrete, stucco, asbestos siding, pressure-treated/pre-treated lumber, masonry, or corrosive non-metallic landscaping materials that might become repeatedly wet

WINDOW AND DOOR TRIM: GABLE END TRIM

TRIM

- J-Channel is used around windows and doors to receive siding. Side J-Channel members are cut longer than the height of the window or door and notched at the top as shown. Notch the top J-Channel member at a 45° angle and bend tab down to provide flashing over side members. Caulking should be used behind J-Channel members to prevent water infiltration between window and channel. Do not caulk siding inside of J-Channel as a method to seal.

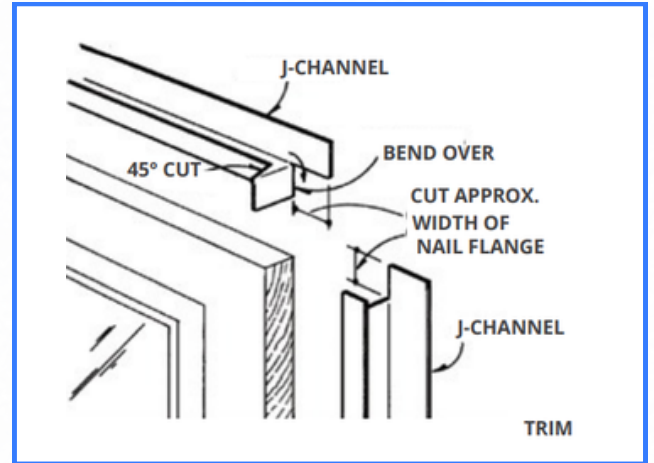

FLASHING

- To further prevent water from getting behind siding, a flashing piece may be cut from coil stock and slipped under the base of the side JChannel members and positioned so as to lap over the top lock of the panel below (see illustration).

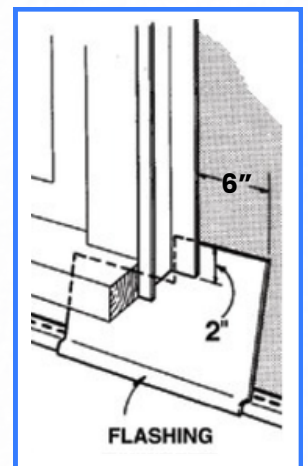
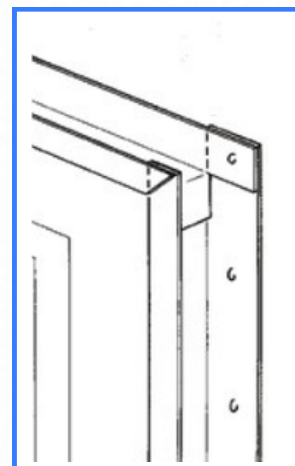

FLASHING

- Before applying siding, J-Channel should be installed to receive siding at the gable ends. Where the left and right sections meet at the gable peak. Let one of the sections butt into the peak with the other section overlapping. A miter cut is made on the face flange of this piece for better appearance. All old paint buildup should be removed before installing J-Channels. Nail every 12" to 16".

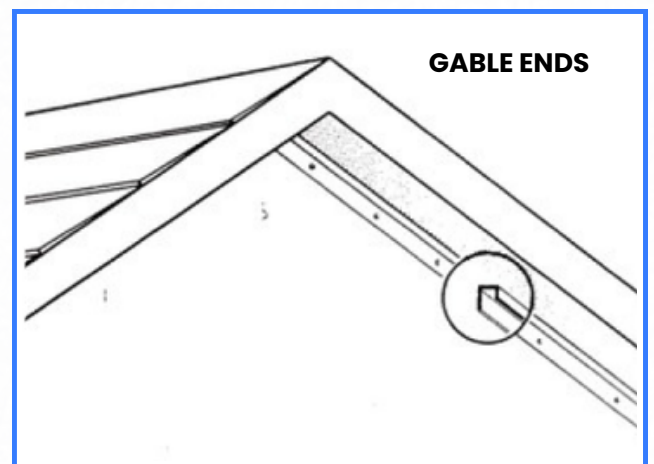

CUTTING PROCEDURES

POWER SAW: STEEL

- Typically, steel should not be cut using any heatgenerating device such as an electric circular saw or jigsaw—to do so may destroy the protective galvanized coating and damage the siding.



TIN SNIPS: STEEL

- Individual panels can be cut with tin snips. Start by drawing a line across the panel using a square. Begin cutting at the top lock first and continue toward the bottom of the panel. Break the panel across the butt edge and snip through bottom lock. Use a screwdriver to reopen lock which may become flattened by tin snips (see drawing). aviation shears are sometimes used to cut the top and bottom locks and a utility knife is used to score and break the face of the panel. For straight cuts, the best choice is duckbill snips.

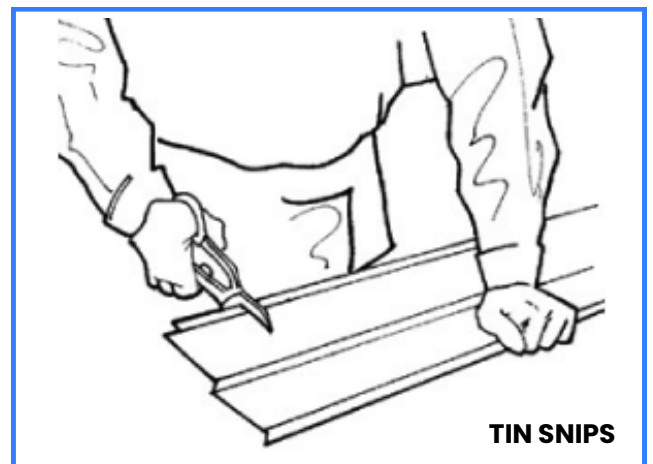

SIDING CUTTER: STEEL

- A guillotine type cutting device designed to cut at vertical right angles to siding. Interchangeable blades for cutting 4" and 5" profiles are available.

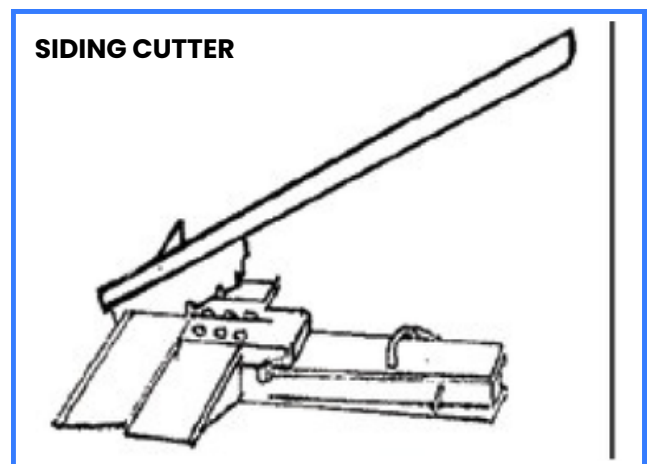

CUTTING PROCEDURES

SCORE & SNAP METHOD: STEEL

- The utility knife is useful for cuts lengthwise as well as cuts across a single panel. A heavy score is made on the face panel and the piece is bent back and forth until it snaps cleanly along the score line. On window cutouts the combination of utility knife and tin snips is most efficient.
- Accessories such as snap-lock finish trim, J Channel, and starter strip can best be cut using duckbill tin snips. Use a hacksaw to cut accessories like corner bases.

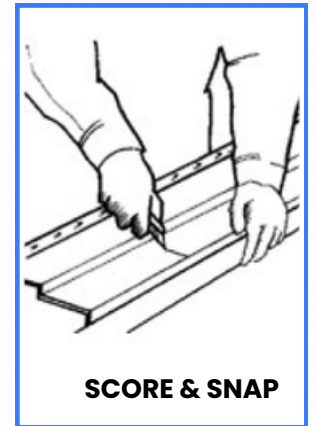
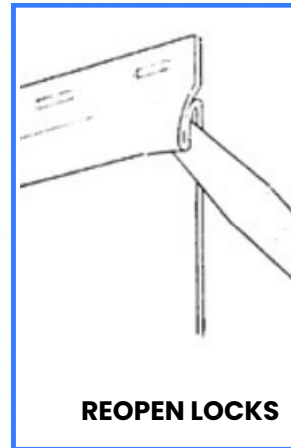

INSTALLING THE SIDING

FIRST COURSE

- Extra care must be taken on the first course of siding applied because this course establishes the base for all other courses. Apply panel by hooking the bottom lock of the panel into interlock bead of starter strip. Make sure lock is engaged. Do not force or jam, which might cause distortion of the panel and result in an undesirable shadow line. Double check for continuous locking along panel before proceeding further. Particularly check for alignment at corners. The first course should be installed a minimum of 6" from the ground.
- At corner bases, slide panel into recess first, then exert upward pressure to lock the panel into place along its entire length.
- Allow clearance for expansion as necessary (see below). Panels must be hung with nails through the center of the factory-slotted holes every 16" to 24" along their entire lengths. Nail must be driven into sound lumber, such as: 3/4" penetration into house framing with plain shank nails or through 1/2" plywood with screw or ring shank nails.

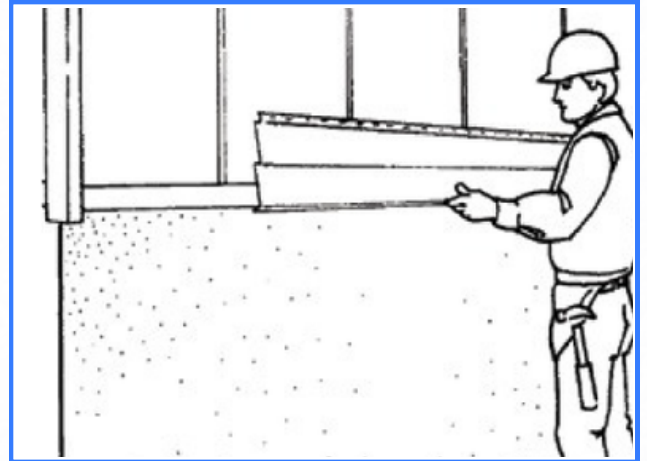

FIRST COURSE

- Metal siding will expand when heated and contract when cooled. the expansion can amount to approximately 1/8" in a 10' length for every 100° of temperature change. Allowance for this expansion or contraction should be made when installing siding. If siding is installed in hot weather, the product is already warm and at least partly "expanded," therefore less room will be required to allow for temperature expansion. With the product stored in a hot sun area, the applicator could apply the siding panel against a corner base with minimum clearance (1/16"). In cold weather, assuming the product was stored in the outside cold, the applicator should allow approximately 1/8" space between areas of possible restriction, such as at a corner base.
- Using this expansion and contraction "common sense," the applicator should be able to install the products properly for good appearance, and thus avoid unnecessary waves or buckles which could occur with temperature change.



NAILING AND STAPLING

HANGING THE SIDING

- When nailing, drive the nail through the center of the factory-slotted hole to within $1/32$ " of the nailing flange, snug but not tight. The slots are elongated to permit the siding to contract and expand freely. Siding nailed too tightly may not be able to move with temperature changes and may also produce an unattractive wavy appearance. Expansion requirements vary with seasons. An application installed in the hot summer requires less allowance. An application installed in winter may require as much as $1/8$ " expansion allowance per panel.

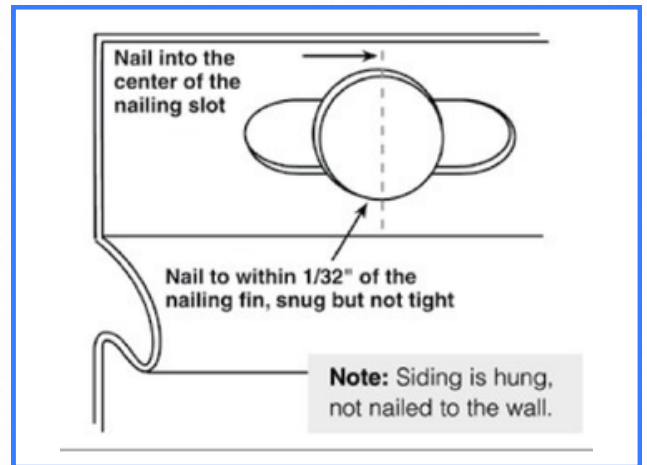

NAILS

- When nailing siding and accessories, always use the correct size nails. Nails should be driven straight and level, never slanted up or down so as to possibly cause distortion of the panel. Use $1-1/4$ " nails (or longer) for siding, as well as most trim accessories. A minimum $3/4$ " penetration into studs with plain shank nails, or penetration through $1/2$ " plywood with screw shank nails is recommended. Where visible nails are required, use trim nails that match the siding or accessory.

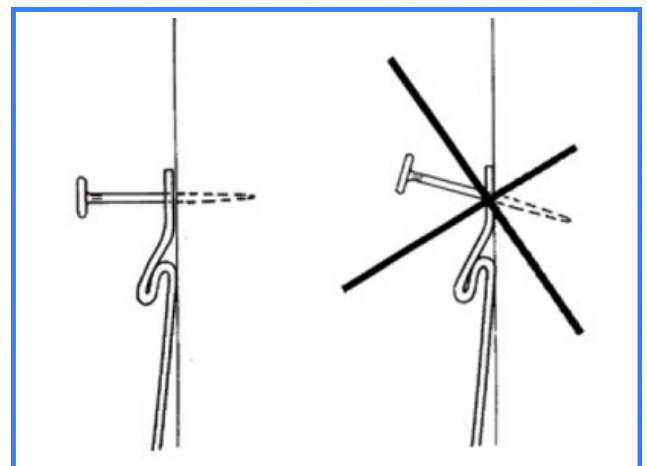

NAILING CENTERS

- Siding nails should be spaced on approximately 16" centers (maximum of 24"). Where low spots are encountered in a wall, drive the nails on both sides of the low spot and allow the panel to float over the low spot to maintain a straight shadow line. On new construction, nail into the studs on 16" centers. Do not skip studs. In remodeling, when siding is installed over old wood, be sure that rotted or broken boards are not used as the nailing base.

NAILING AND STAPLING

PNEUMATIC STAPLERS/NAILERS

▶ Power fasteners are an accepted alternative method of installing siding. The same care must be taken as when you nail by hand. Drive the fastener through the center of the factory-slotted hole to within $1/32$ " of the nailing flange, snug but not tight. The fasteners must be corrosion-resistant, such as cadmium-coated or galvanized steel. The fasteners must be long enough to penetrate into a solid substrate at least $3/4$ ".

▶ The staple crown will be a minimum width of $3/8$ ". Check the gun, air pressure and your technique on the first course and make the necessary adjustments. Always follow the pneumatic power fastener manufacturers' instructions for safe and proper use of their guns.

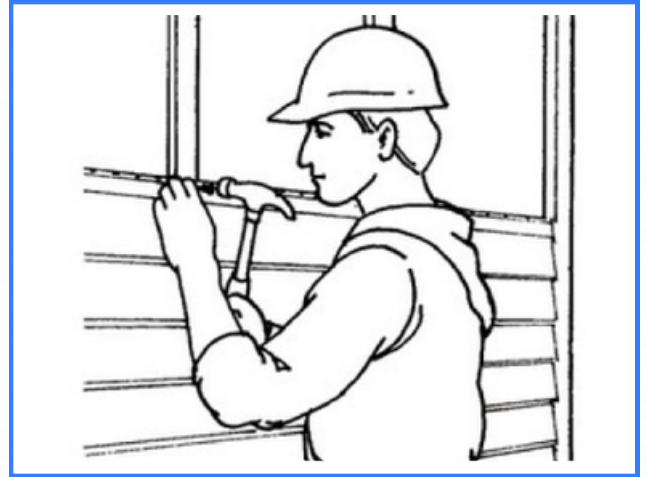

PANELS AT WINDOWS AND DOORS

MEASURING

- As siding courses reach a window, a panel will probably need to be cut narrower to fit the space under the window opening. Plan this course of siding so that the panel will extend on both sides of the opening.
- Hold the panel in place to mark for the vertical cuts. Use a small piece of scrap siding as a template, placing it next to the window and locking it into the panel below. Make a mark on this piece 1/4" below the sill height to allow clearance for snap-lock finish trim. Do the same on the other side of the window, since windows are not always absolutely level.

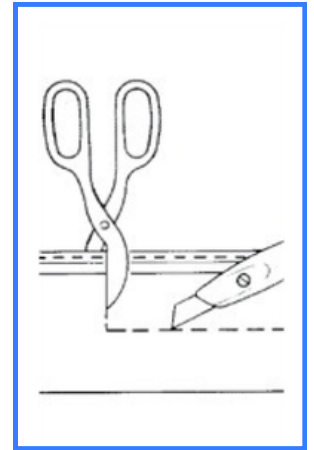
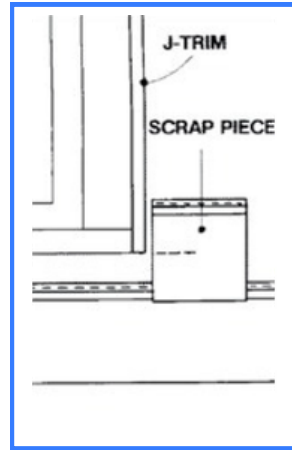

CUTTING

- The vertical cuts are made with duckbills, tin snips, or power saw* from top edge of panel. The lengthwise (horizontal) cut is scored with the utility knife one time, and bent back and forth until the unwanted piece breaks out.

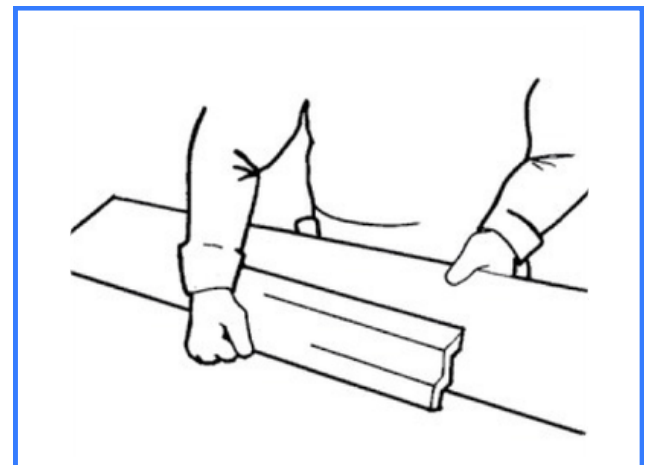

TRIMMING AND FURRING

- The raw cut edge of the panel should be trimmed with a sill trim the exact width of the sill. First determine if furring is required behind the cut edge to maintain slope angle with adjacent panels. Nail the correct thickness of furring under the sill and install sill trim over it, nailed close up under the sill for a tight fit.

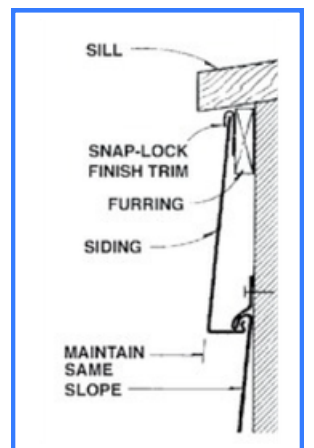
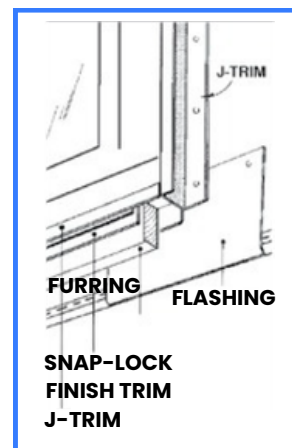

INSTALL

- With a snap-lock punching tool, punch slots every 12" to 16" along top 1/4" of panel. Slide the panel upward so as to engage the sill trim, the Jchannels on window sides, and the lock of the panel below.

PANELS AT WINDOWS AND DOORS

MEASURING AND CUTTING

- ▶ Fitting panels over door and window openings is almost the same as making undersill cutouts, except that clearances for fitting the panel are different.
- ▶ The cut panel on top of the opening needs more room to move down to engage the interlock of the siding panel below, on both sides of the window. Mark a scrap piece template without allowing clearance, and then make cuts $1/4''$ to $3/8''$ deeper than the mark. This will provide the necessary interlock clearance.

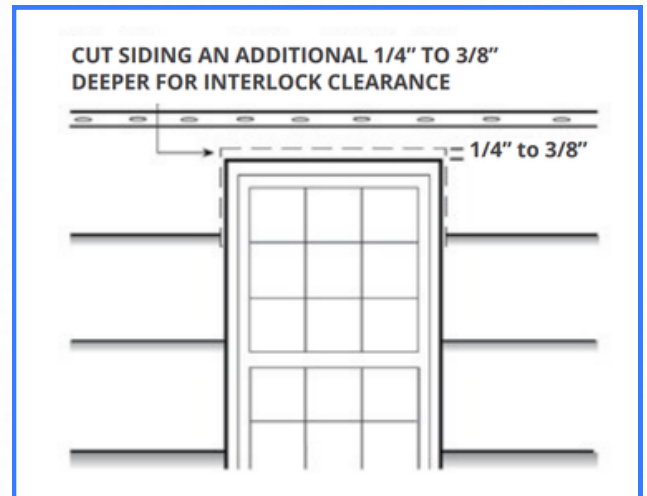

FURRING

- ▶ Check the need for furring over the top of window or door in order to maintain slope angle, and install if required.

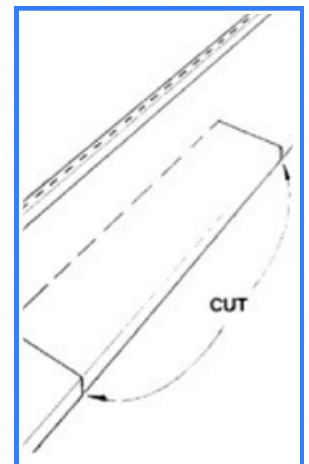
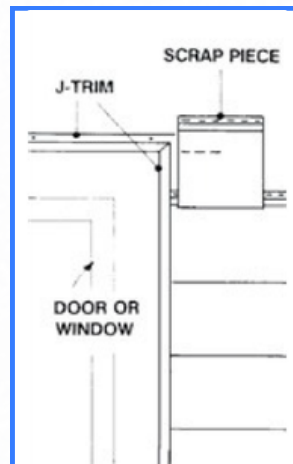

TRIM

- ▶ Cut a piece of sill trim the same width as raw edge of cut panel, and slip over this cut edge in the panel before installing.
- ▶ Drop panel into position engaging interlocks on siding panels below. The sill trim can now be pushed downward to close any gap noticeable at juncture with J-channel.

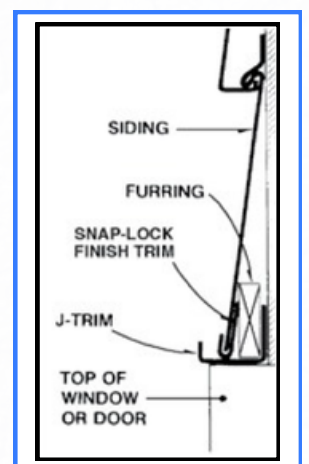
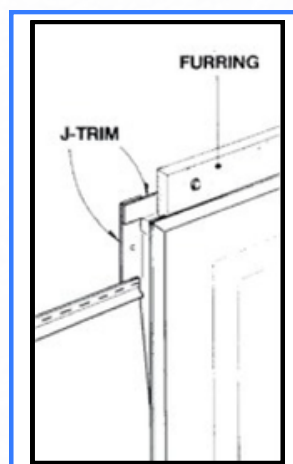

FITTING AT GABLE ENDS

MEASURING AND CUTTING

- When installing siding on gables, diagonal cuts will have to be made on some of the panels. To make a pattern for cutting panels to fit the gable slope, use two short pieces of siding as templates. Interlock one of these pieces into the panel below. Hold the second piece against the J-channel trim on the gable slope. Along the edge of this second piece, scribe a line diagonally across the interlocked panel and cut along this line with tin snips or power saw. This cut panel is a pattern which can be used to transfer cutting marks to each successive course along the gable slope. This pattern should be checked on each course for accuracy, as the slope is not always straight. All roof slopes can be handled in the same manner as gable end slopes.

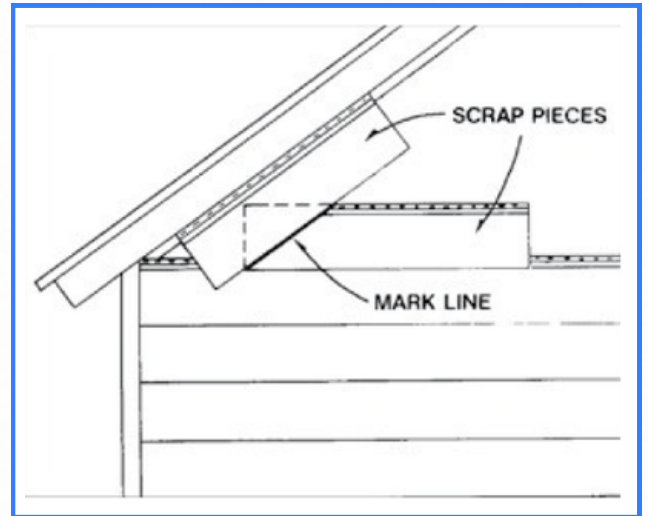

INSTALLATION

- Slip the angled end of panel into J-trim previously installed along gable edge. Lock the butt into interlock of the panel below. Remember to allow for expansion or contraction where required. If necessary, face nail with 1-1/4" (or longer) painted head nail in the apex of the last panel at the gable peak. Touch-up enamel in matching siding colors can also be used for exposed nail heads.
- Do not cover existing louvers. Attic ventilation is necessary in summer to reduce temperatures, and in winter to prevent the accumulation of moisture.

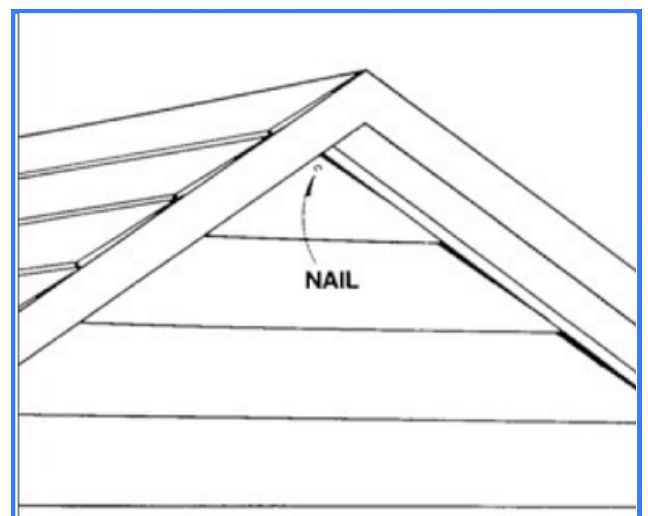

FITTING UNDER EAVES

FURRING

- The last panel course under the eaves will almost always have to be cut lengthwise to fit in the remaining space. Usually furring will be needed under this last panel to maintain correct slope angle. Determine proper furring thickness and install.
- Nail the sill trim to the Furring strip, flush with the eave line. Trim should be cut long enough to go the length of the wall.

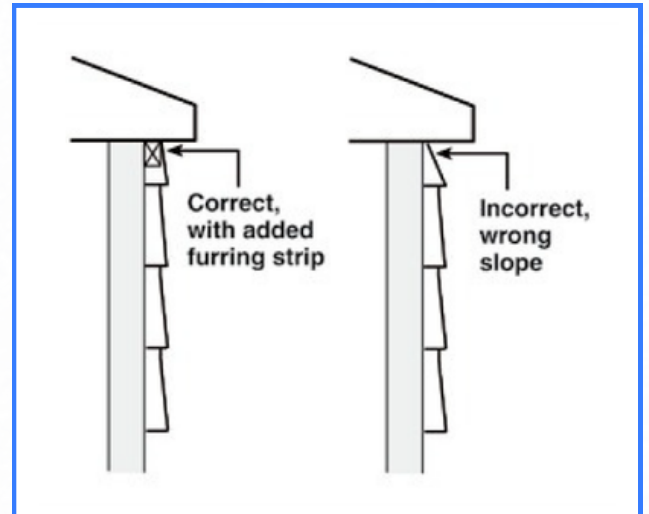

CUTTING

- To determine width of cut required, measure from bottom of top lock to eaves, subtract 1/4" and mark panel for cutting. Take measurements at several points along the eaves to ensure accuracy.
- Score the face of the panel with the utility knife and bend until it snaps. With punch tool, punch notches every 12" to 16" along top of panel, 1/8" to 1/4" from edge of panel.

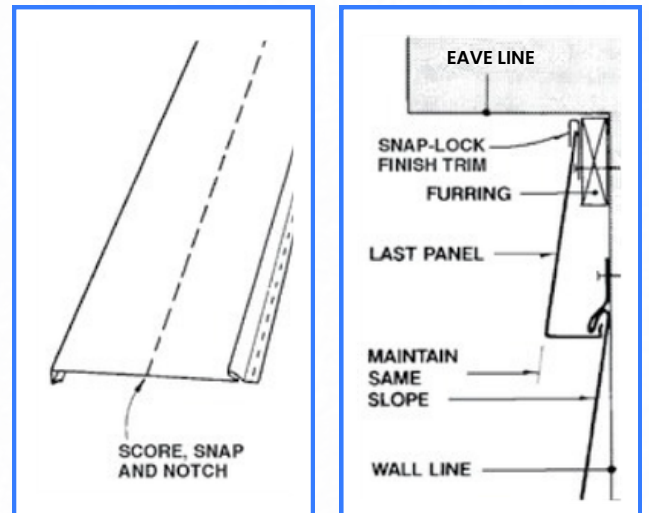

INSTALLATION

- Slide the panel into the sill trim, making sure to engage the interlock of the panel below. It may be necessary to gently tap the siding panel into place using a hammer and a 2' to 3' long piece of lumber.
- With this technique, face nails will not be required.

VERTICAL SIDING

APPLICATION

- Vertical siding is used both for an entire installation and as a contrast to horizontal siding, especially on gable ends. Most procedures outlined for horizontal siding are generally the same for vertical siding except that the starter strip is applied vertically and panels interlock in a vertical position.

ACCESSORIES AND STARTER STRIP

- Snap a chalk line, which is parallel to the eaves or the window heads, along the base of the house as a guide for applying vertical base flashing trim (or J-channel). apply J-channels under the eaves. Add outside corner bases as required. Windows and doors are trimmed with J-channel on the sides and under sills, with vertical base flashing (or J-channel) being used at the window heads. To locate the starter strip, drop a plumb line from the gable peak off-center by one half the width of a vertical panel batten, and mark a chalk line. The starter strip bottom edge is nailed to this line (see drawing). The raised batten will now be correctly centered for best appearance.

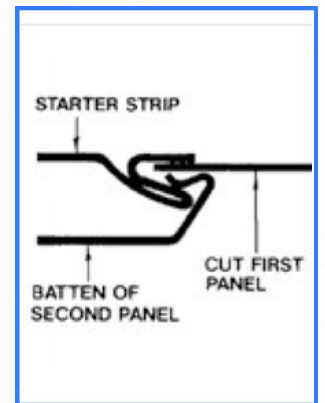
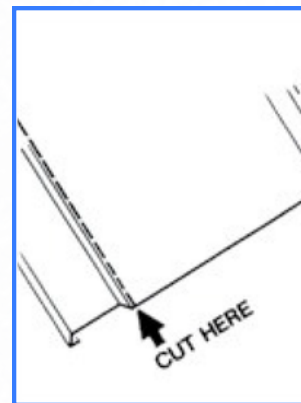
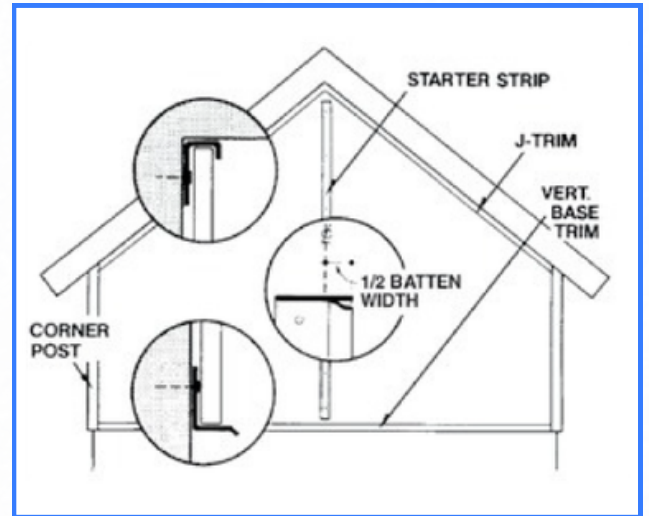

FIRST PANEL

- Measure and cut the first panel to correct length. Cut the batten edge off this panel. Slip the cut edge under the starter strip and nail panel through slotted nailing flange. Cut the other panel to correct length, and engage batten flange in starter strip and nail panel (see drawing).

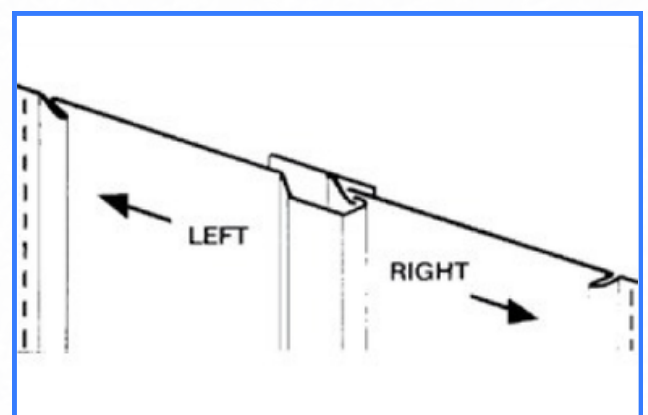

VERTICAL SIDING

REMAINING PANELS

- It will now be possible to continue the installation working in both left and right directions from these two initial center panels (see drawing), which makes for an even-spaced batten appearance when there is a gable. An alternative way to install the starter strip is to nail it plumb at the corner and install panels working from one direction.

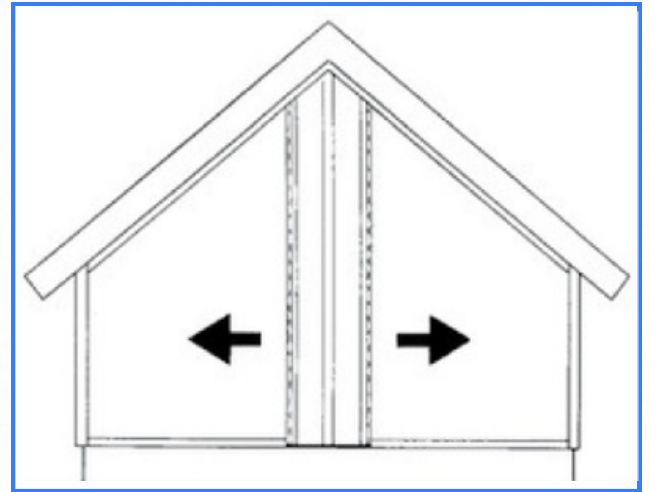

DOORS AND WINDOWS

- Panel fitting around door and window trim is similar to that shown for horizontal siding. The cut edge of the vertical panel is capped with snap-lock finish trim and inserted into a J-Channel. Furring out may be required, depending on where the cut is made (for instance, if the cut is made in the batten portion of the panel). The procedure at inside and outside corners would also be the same as for horizontal siding. The Snap-Lock finish trim must be nailed before installing the vertical panel. It can be held in place by punching a notch every 12" to 16", with a snap-lock punching tool, 1/4" from edge of panel.

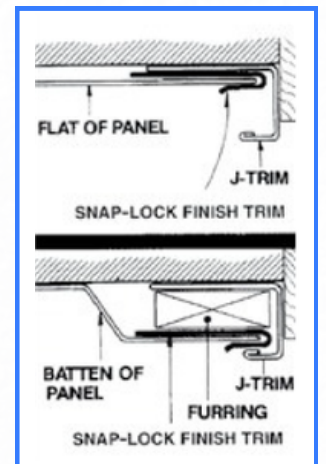
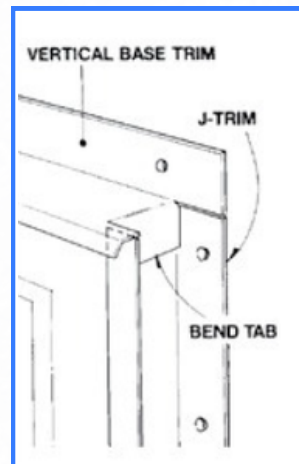

VERTICAL SIDING

PANEL BENT CORNERS

- At outside corners, a panel can be bent around the corner rather than using an outside corner base. Cut the panel to correct length and lock into previous panel. Mark where the panel should be bent around corner and remove panel. Use a portable brake and bend to form right angle. Install panel and nail in place. Continue with next vertical panel as usual, on adjoining wall.

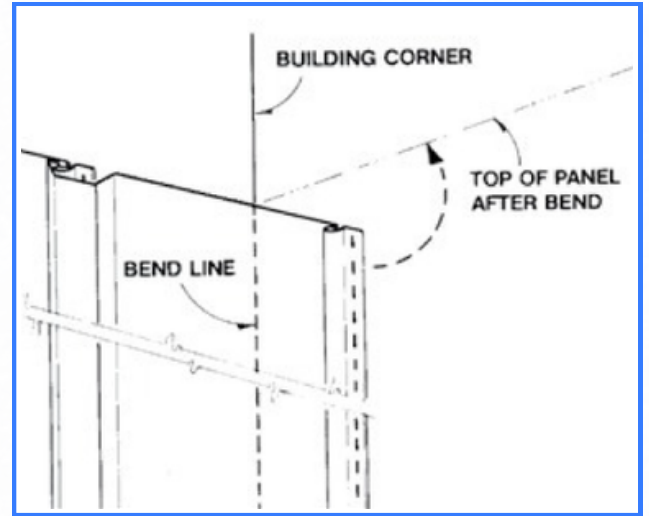

NARROW CUT PANELS

- When panels are cut narrower to fit into corners, at the end of a run for example, the raw edge can be trimmed using snap-lock finish trim and notched every 12" to 16" with a snap-lock punching tool, 1/4" from edge of panel.

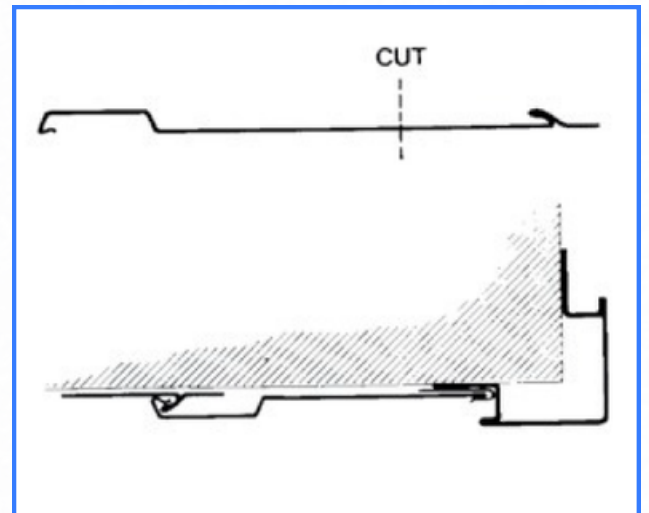

CAULKING AND CLEANUP

CAULKING

- In general, caulking is done around doors, windows, and gables where metal meets wood and metal meets metal, except where accessories are used to make caulking unnecessary. (Do not caulk siding inside of J Channel as a method to seal.)
- Caulking is also needed where metal meets brick or stone around chimneys and walls. Try not to use exposed caulking on top of siding panels. Surface caulking required at panel cutouts around faucets, meter boxes, etc., must be done neatly.

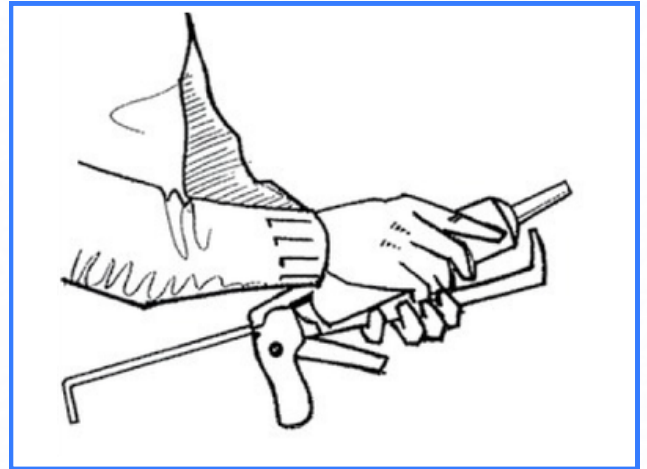

- It is important to get a deep caulking bead (1/4" minimum), not just a wide bead. Cut the plastic tip of the caulking cartridge square to get this deeper bead. Move the gun evenly, and apply steady, even pressure on the trigger.
- Preferred caulking's are the butyl or silicone types, such as Geocell 2300, as they have greater flexibility. Most producers supply caulking in colors to match siding and accessories. Do not depend on caulking to fill large gaps (more than 1/8" wide), as expansion/contraction of the siding may cause cracking of the caulking.

CLEAN UP

- Keep hands as clean as possible during application, or use clean work gloves. To clean smudges, use a soft cloth or damp sponge dipped in mild detergent solution or in soap and water. Avoid rubbing too hard which might create a glossy area on the finish surface. Never use harsh abrasive cleaners.
- For asphalt or grease stains, mineral spirits can be used with care. Thoroughly clean off any residue, then rinse off any soap/water and dry.

JOBSITE

- Reinstall all fixtures, brackets, downspouts, etc., that were removed. Many applicators paint accessories that weren't replaced (such as kitchen fan outlets or service cable) to match the new siding color. Most manufacturers have available touch-up paint or matching paint formulas which can be purchased.
- All scrap pieces, cartons, nails, etc., should be removed and the jobsite left neat and clean each day. Installers should also use a magnet to clean up nails and other metal shavings around the jobsite.

REPAIRS AND MISCELLANEOUS

REPLACEMENT OF DAMAGED PANEL

1. Cut damaged panel just above center with utility knife for entire length of panel. Discard the bottom cut section of damaged panel. Do not nail remaining part of damaged panel, as this will not allow for expansion/contraction.
2. Remove top lock of a new panel by scoring with utility knife. Bend and snap off. Remove burrs on scored edge. Try small piece of siding panel to fit under old lock. If too tight, carefully open with wide putty knife.
3. Apply heavy bead of caulk full length of damaged panel at point shown in drawing.
4. Install new panel carefully over caulk. Engage top and bottom of panel into respective locks. Be sure caulk makes contact with new panel. Apply pressure with palm of hand. Do not nail panel. use this procedure on all siding.

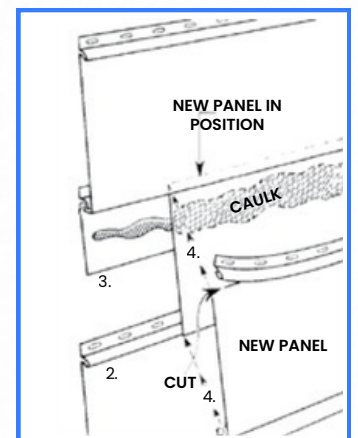
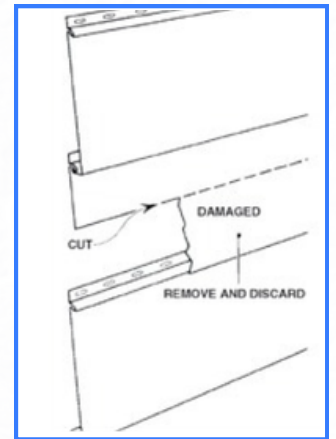

TRANSITIONS

1. Vertical over Horizontal – Cut nailing flange and lock off last horizontal panel course and fur out if necessary.
2. Horizontal over Vertical – use J-Channel to cap off vertical. Then use vertical base trim and starter strip to start horizontal panels.

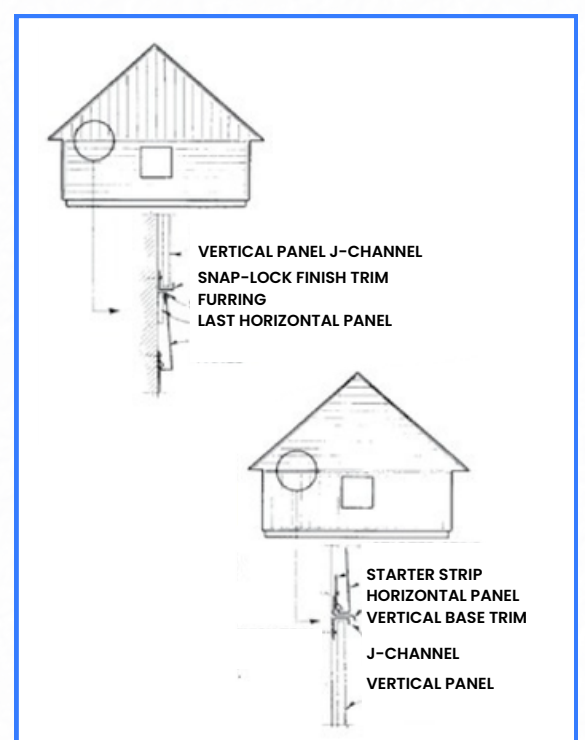

REPAIRS AND MISCELLANEOUS

SHORT PANELS BETWEEN OPENINGS

- For runs between windows, nail J-Channels on both sides of the space. Bow the siding to slip into channels. If the space is too narrow to allow the bowing of panels one J-Channel can be left unattached initially.
- This J-Channel can be nailed in position as successive panels are nailed in place. A nail set may be used to seat nails within the J-Channel to prevent damage.

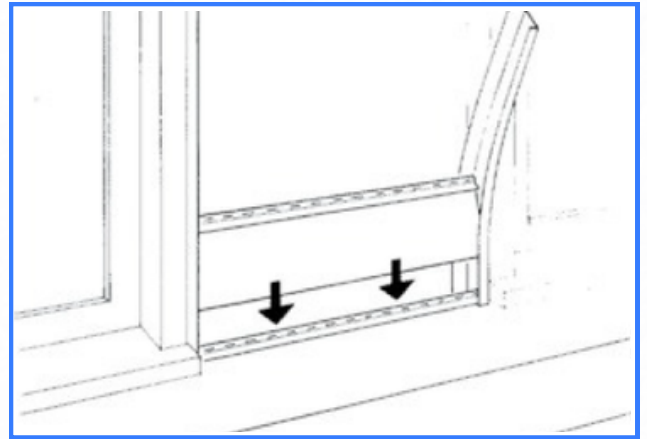

DIFFICULT CONDITION STARTER STRIP APPLICATION

- The procedure shown can be used where conventional starter strip is too narrow to fit uneven base line, or where broken shingles or boards make installing the starter strip difficult or impossible.
- To solve the problem cut the butt end from a siding panel and install it upside down, inside out, against the base line of the house. The first panel course is then engaged in a normal manner as shown.

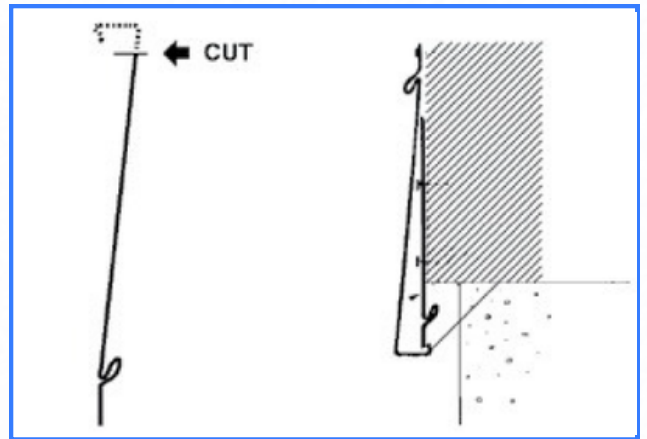

SOFFIT AND FASCIA

- Soffit systems go up easily and utilize many of the techniques described earlier in the book. The following steps explain the procedure.

WALL RECEIVERS

- 1. J-Channel is a popular wall receiver used to receive soffit panels.
- 2. Install wall receiver at the wall line into existing soffit or outlookers (in new construction) with screws. nails should penetrate 3/4" solid lumber.
- 3. If soffit has open rafters as shown, the wall receiver should be nailed to a chalked line level with the sub-fascia.
- 4. The wall receiver can be cut with tin snips, and nailing tabs can be bent up as shown, for nailing into side wall.

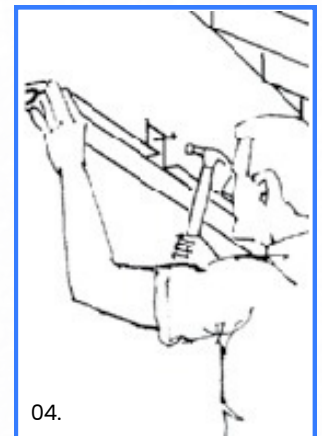
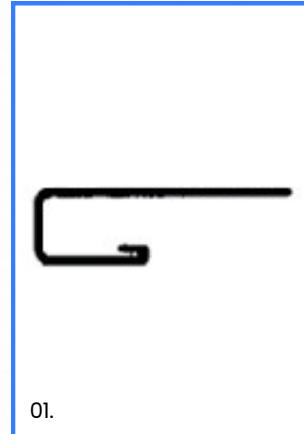

NAILING PANELS

- Cut panels to desired length to insert into wall receiver and line up flush with outside face of subfascia. Fit panel interlocks together and nail through using trim or siding nails.
- 5. Intermediate nails are required 24" O.C. soffit panels 36" in length require a center nail at 18". Any soffit panel length over 36" requires a center nail at least every 36". It is also recommended to center nail soffit panels on any building over three stories high. Use a pattern of vented and nonvented panels to provide good ventilation from the soffit. Check local building codes for recommended ventilation requirements.

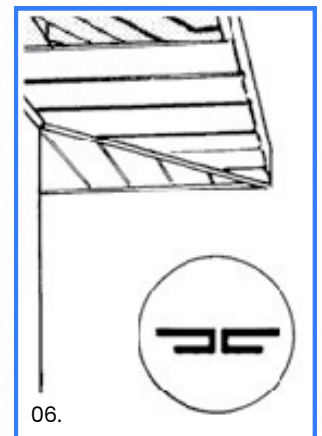

Note: Ribs or grooves should be installed to line up at the miter.

SOFFIT AND FASCIA

MITER CORNERS

- 6. When soffit overhangs on both walls are of equal dimension, the miter should be installed at a 45° angle to the wall receiver. Panels are cut at a 45° angle, slipped into the opening in the miter and nailed in place.

MITER CORNERS

- 7. When overhang dimensions are not equal on both sides, install the miter molding parallel with the largest dimensions. Ribs or grooves will not line up on this application.

FASCIA

- Various styles and height dimensions are available.
- 8. Never face nail steel fascia. Face nailing can result in a wavy or buckled appearance during thermal expansion cycles. Always use a drip edge, gutter or snap-lock finish trim to receive cut top edge of fascia. If face nailing is the only option, pre-drill holes larger than the nail.
- 9. Nail underside of fascia as shown. Keep nails lined up with soffit V-grooves for best appearance. nail every 24", but do not nail too tight.
- Many times it is necessary to use trim sheet bent on a portable brake to the special fascia shapes. Nail the special fascia the same way. nails should penetrate a minimum of 3/4".

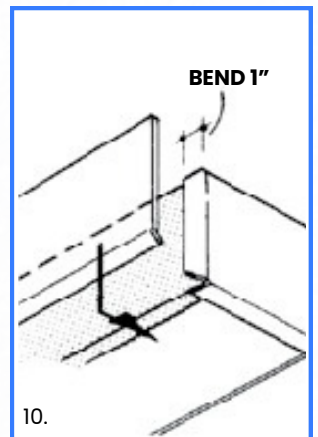
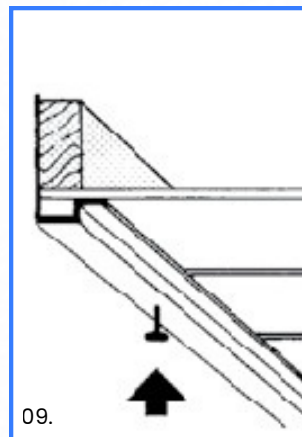
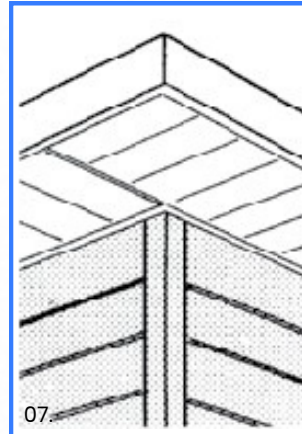

OUTSIDE CORNER FASCIA

- 10. Bend 1" flange on the first fascia piece, 90° around corner. Cut overlapping fascia at 45° angle. nail with appropriate colored trim nails.

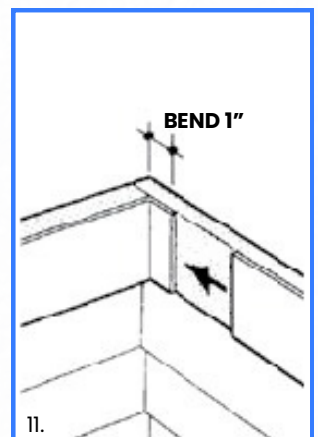

INSIDE CORNER FASCIA

- 11. Use the same technique as for outside corner.

BUY DIRECT

AND SAVE!

Contact Us:



269215-2003



info@themetalshopllc.com



www.themetalshopllc.com



**12945 S M-66 HWY
Bellevue, MI 49021**

Follow us on:   